

# **PRESSURE EQUIPMENT CALCULATOR APP**

EN 13445-3:2014/2018

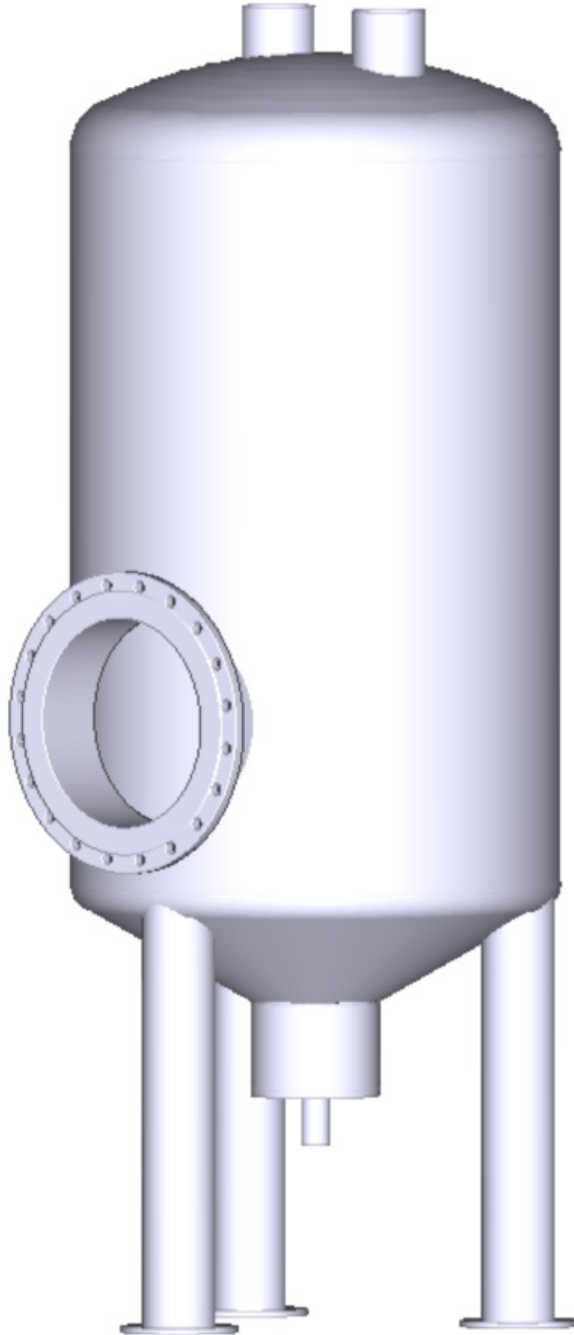

## **USER MANUAL**

**Version 1.0**

**©2020 – Maticon Consulting Engineers**

## TABLE OF CONTENTS

Introduction	1
About Pressure Equipment Calculator App	1
Copyright	2
Terms of Use	2
Disclaimer	2
Materials	3
Joint Coefficient	3
Cylindrical Shell – Design- And Dimensional Data	4
Cylindrical Shell – Results	5
Conical Shell – Design- And Dimensional Data	6
Conical Shell - Results	7
Klöpfer/Korbbogen End – Design- And Dimensional Data	8
Klöpfer/Korbbogen End - Results	9
Ellipsoidal End – Design- And Dimensional Data	10
Ellipsoidal End – Results	11
Hemispherical End – Design- And Dimensional Data	12
Hemispherical End – Results	13
Welded Flat End – Design- And Dimensional Data	14
Welded Flat End – Results	15

## **INTRODUCTION**

Pressure Equipment Calculator App – EN 13445, is a mobile application which calculates minimum thicknesses for pressure equipment components, according to the European PED harmonized standard, EN 13445, for unfired pressure vessels.

The application covers calculation of:

- Cylindrical shells
- Conical shells
- Klöpfer heads (torispherical heads)
- Korbogen heads (torispherical heads)
- Elliptical heads
- Hemispherical heads and shells
- Welded flat ends

Calculations can be carried out for internal and external pressure in all modules.

Calculations are carried out for the design- and the testing situation.

Testing pressure is calculated according to EN 13445-5.

The application includes the possibility to calculate unreinforced openings in all modules.

Minimum distance between unreinforced opening and shell discontinuity are calculated.

For klöpfer, korbogen and elliptical heads it is possible to calculate openings in the knuckle region.

588 materials are included covering all parts of EN 10028 (plate), EN 10216 (seamless tubes) and EN 10217 (welded tubes).

Allowable stresses are calculated automatically based upon the given temperature and chosen testing group.

Warnings and errors are generated if criterions within EN 13445 are not fulfilled.

All calculated thicknesses are printed, with high-lightening of the maximum value.

There is a possibility to save, print or email the calculated results.

This tool can be used by manufactures during the preliminary design phase or when putting together an offer for a customer.

Technical personal can easily obtain quick results during inspection of old, corroded, in-service pressure equipment.

The application can also be used during QA of the final technical documentation or by notified bodies/inspection agencies when evaluating technical documentation.

## **ABOUT PRESSURE EQUIPMENT CALCULATOR APP**

PE Calculator (EN 13445) has been developed by Maticon Consulting Engineers.

Current version: EN 13445-3:2014/Issue 5:2018.

For information about our services, help, and tutorials, please visit our website: [www.maticon.eu](http://www.maticon.eu)

## **COPYRIGHTS**

© 2020 Maticon. All rights reserved.

Maticon  
Betonvej 10  
DK-4000 Roskilde  
Denmark  
T: +45 32 100 200  
E: [app@maticon.dk](mailto:app@maticon.dk)  
W: [www.maticon.eu](http://www.maticon.eu)

The product- and material standards: DS/EN 13445, DS/EN 10028, DS/EN 10216 and DS/EN 10217, has been used with kind permission by the Danish Standard Foundation.

© DS 2020. All rights reserved. Unless otherwise specified, no part of this publication may be reproduced or utilized otherwise in any form or by any means, electronic or mechanical, including photocopying, or posting on the internet or an intranet, without prior written permission. Permission can be requested from DS at the address below.

Danish Standards Foundation  
Göteborg Plads 1  
DK-2150 Nordhavn  
Denmark  
T: +45 39 96 61 01  
E: [danskstandard@ds.dk](mailto:danskstandard@ds.dk)  
W: [www.ds.dk](http://www.ds.dk)

## **TERMS OF USE**

PE Calculator (EN 13445) has been developed by Maticon and is intended to be used to estimate minimum thicknesses for pressure equipment according to the European standard for unfired pressure vessel, EN 13445, using materials that are harmonized with the European Directive for Pressure Equipment, 2014/68/EU.

Appropriate input values and materials must be used in order to obtain realizable calculation results.

## **DISCLAIMER**

PE Calculator (EN 13445) has been developed by Maticon with main focus on accuracy and high quality in order to have a reliable and well-functioning mobile application, but errors, inaccuracies, mistakes, malfunction, omissions etc. may occur.

The user shall, at any time, have the application updates enabled and ensure that all previous updates were installed in order to ensure the application's proper functioning.

The user shall only use the application with compatible devices. Maticon shall not be responsible for any damages being a result of improper use of the application, including, but not limited to, using the application on devices it was not designed for.

Maticon assumes no responsibility for errors, inaccuracies, mistakes, malfunction, omissions etc. in our mobile application or documentation, examples and guidelines available from our website.

In no event shall Maticon be liable to the user or any third parties for any special, punitive, incidental, indirect or consequential damages of any kind, or any damages whatsoever, including, without limitation, those resulting from loss of use, data or profits, whether or not Maticon has been advised of the possibility of such damages, and on any theory of liability, arising out of or in connection with the use of this mobile application.

The use of the mobile application is done at your own discretion and risk and with agreement that you will be solely responsible for any damage to your operating system or loss of data that results from such activities. No advice or information, whether oral or written, obtained by you from the Maticon or from the Maticon website shall create any warranty for the mobile applications.

## **MATERIALS**

588 materials are included from the PED harmonized material standards:

- EN 10028, part 1 to 7 (plate material)
- EN 10216, part 1 to 5 (seamless tubes)
- EN 10217, part 1 to 7 (welded tubes)

Design- and testing stresses are calculated automatically acc. to EN 13445-3, Table 6-1, based upon the yield- and strength values at the given temperature.

At high temperatures creep properties for the used material should be investigated. That is typically around, but not limited to, 370° C for ferritic steels and 425° C for austenitic steels. Design due to creep is not included.

A thickness range for the material must also be selected, as the yield- and strength values also depends upon the material thickness. A sub-menu opens automatically when selecting the material.

## **JOINT COEFFICIENT**

The joint coefficient depends upon the chosen testing group. EN 13445-5, Table 6.6.1-1 should be used to select a proper joint coefficient.

The following joint coefficients are included in the Pressure Equipment Calculator app:

- 1.00 Testing group 1 and 2 (Full NDT)
- 0.85 Testing group 3 (Random NDT)
- 0.70 Testing group 4 (No NDT)
- 1.00 Seamless part

For austenitic, seamless, cold-spun torispherical ends, it is possible to select a special 1.00 joint coefficient, which can reduce the thickness, compared to the regular 1.00 joint coefficient for seamless parts.

Some guidelines for choosing the testing group:

### *Testing group 4:*

- Only group 2 fluids (non-dangerous fluids)
- max. 20 bar(g) internal pressure
- max. P·V (pressure · volume) 20.000 bar·liter above 100° C
- max. P·V (pressure · volume) 50.000 bar·liter up to 100° C
- non-cyclic pressure vessels (max. 500 full-pressure cycles)
- Only group 1.1 and 8.1 materials (see CEN ISO/CR 16508:2000)
- Max. 16 mm material thickness

### *Testing group 3*

- Only group 1.1, 1.2, 8.1, 8.2, 9.1, 9.2, 10 materials (see CEN ISO/CR 16508:2000)
- Max. 30-50 mm material thickness

### *Testing group 1 and 2*

- "Otherwise" (not suitable in testing group 3 and 4)

## CYLINDRICAL SHELL – DESIGN- AND DIMENSIONAL DATA

### Internal design pressure

Enter a positive value greater than zero, i.e. 5 bar gauge. This value is also referred to as Pi. Default value is 0 bar gauge.

### External design pressure

Enter a positive value greater than zero, i.e. 1 bar (which equals full vacuum). If the absolute value of the external pressure is greater than the internal pressure, then the internal pressure automatically is set to the same value as the external pressure, ref. EN 13445-3, Sec. 5.3.4. This value is also referred to as Pe. Default value is 0 bar gauge.

### Design temperature

Enter a positive value greater than twenty, i.e. 225 °C. Values below 20 °C is automatically set to 20 °C. This value is also referred to as TS. Default value is 20 °C.

### Joint coefficient

Select a proper joint coefficient acc. EN 13445-5, Table 6.6.1-1:

- 1.00 Testing group 1 and 2 (Full NDT)
- 0.85 Testing group 3 (Random NDT)
- 0.70 Testing group 4 (No NDT)
- 1.00 Seamless part

Also see page 3.

### Cylindrical shell material

Materials can be chosen from:

- EN 10028, part 1 to 7 (plate material)
- EN 10216, part 1 to 5 (seamless tubes)
- EN 10217, part 1 to 7 (welded tubes)

A thickness range must be selected for the chosen material. A sub-menu opens automatically when selecting the material.

Also see page 3.

### Outer diameter of shell, De

Enter a positive value greater than zero, i.e. 1200 mm. Default value is 0 mm.

### Diameter of opening in shell, do

Enter a positive value greater than zero, i.e. 500 mm. The opening is calculated as an unreinforced opening which is a conservative approach in case a nozzle is present. Default value is 0 mm.

### Unsupported length of shell, Ls

Enter a positive value greater than zero, i.e. 2500 mm. This value is necessary in case an external pressure is present. This value is typically the length between intermediate stiffeners or the length between two major flanges at the end of the cylinder. Default value is 0 mm.

### Drawing

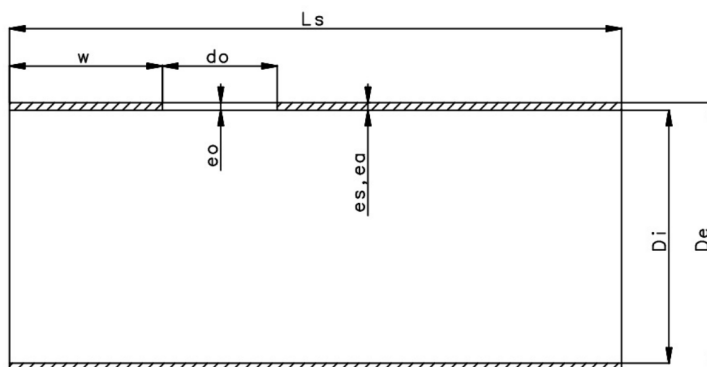

MAIN MENU Cylindrical Shell DRAWING

#### DESIGN DATA

Internal design pressure [bar]

External design pressure [bar]

Design temperature [°C]

Joint coefficient

Cylindrical shell material

#### DIMENSIONAL DATA

Outer diameter of shell, De [mm]

Diameter of opening in shell, do [mm]

Unsupported length of shell, Ls [mm]

CALCULATE

RESET

BACK Joint Coefficient

Please note that there may be special requirements concerning the choice of a proper joint coefficient.

1.00 - Testing Group 1 and 2

0.85 - Testing Group 3

0.70 - Testing Group 4

1.00 - Seamless Part

BACK Material

Grade & Standard	Mat.No.
P265GH EN 10028-2	1.0425
P265GH EN 10217-2	1.0425
P265GH EN 10217-5	1.0425
P265GH EN 10216-2	1.0425
20MnNb6 EN 10216-2	1.0471
P355GH EN 10028-2	1.0473

BACK Material

Grade & Standard: P265GH  
Mat.No: 1.0425

Type	Notes
Plate	Max. 16 mm
Plate	Max. 40 mm
Plate	Max. 60 mm
Plate	Max. 100 mm
Plate	Max. 150 mm
Plate	Max. 250 mm

## CYLINDRICAL SHELL – RESULTS

### Input Parameters

The entered design- and dimensional data are shown as the first section of the results screen.

### Calculated Result

The minimum thickness,  $e_{min}$ , being the maximum calculated thickness for all cases, is shown within this section of the results screen.

### Calculation Info

Within this section various information are shown i.e.:

- Errors discovered during the calculation
- Any correction to the input parameters
- The calculated internal diameter,  $D_i$
- The calculated internal testing pressure,  $PT$
- In case of openings, the minimum distance to any discontinuity,  $w$ , based upon the calculated minimum thickness, are shown
- Allowances (negative, wear, corrosive etc.) should always be added to the calculated results
- Other relevant information

### Calculation Details

This section shows in detail all the calculated minimum thicknesses for the design- and testing situation with reference to formulas within the EN 13445-3 standard.

#### Design Situation

- $e_s(P_i)$ : Cylindrical shell thickness due to the internal pressure,  $P_i$
- $e_o(P_i)$ : Cylindrical shell thickness due to the opening and internal pressure,  $P_i$
- $e_a(P_e)$ : Cylindrical shell thickness due to the external pressure,  $P_e$
- $e_s(P_e)$ : Cylindrical shell thickness due to the external pressure,  $P_e$ , used as internal pressure,  $P_i$

#### Testing Situation

- $e_{st}$ : Cylindrical shell thickness due to the internal testing pressure,  $PT$
- $e_{ot}$ : Cylindrical shell thickness due to the opening and internal testing pressure,  $PT$

The calculated maximum value will be the overall minimum thickness,  $e_{min}$ .

### Further Possibilities

You can save, email or print the calculated results.

### Drawing

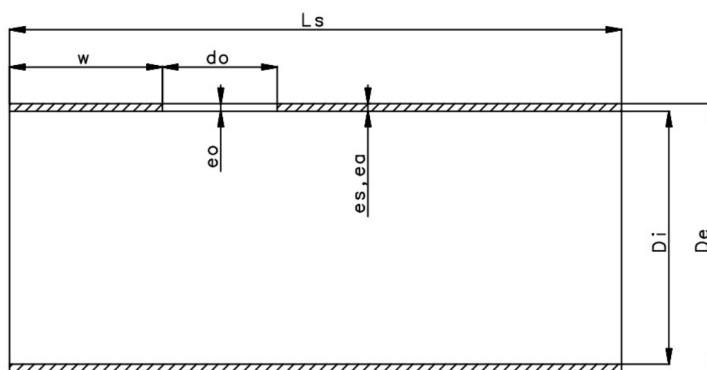
[BACK](#)

Cylindrical Shell

#### INPUT PARAMETERS

Internal design pressure: 5.0 bar  
External design pressure: 1.0 bar  
Design temperature: 225 °C  
Joint coefficient: 0.85  
Cylindrical shell material: 1.0425  
Outer diameter of end,  $D_e$ : 1200 mm  
Opening in cylindrical shell,  $d_o$ : 500.0 mm  
Unsupported length of shell,  $L_s$ : 2500 mm

#### CALCULATED RESULT

Minimum thickness,  $e_{min}$  = 8.1 mm

#### CALCULATION INFO

Min. distance to discontinuity,  $w$  = 98.26 mm  
Distance,  $w$ , based upon calculated  $e_{min}$   
Length,  $L_s$ , should include vessel ends, if applicable (Sec. 8.5.2.1)  
Internal diameter,  $D_i$  = 1183.8 mm  
Internal testing pressure,  $PT$  = 8.2 bar  
**Please add allowances**

#### CALCULATION DETAILS

##### Minimum Thickness - Design Situation

$e_s(P_i)$  = 2.69 mm (Eq. 7.4-2)  
 $e_o(P_i)$  = 8.1 mm (Sec. 9)  
 $e_a(P_e)$  = 5.06 mm (Sec. 8.5.2)  
 $e_s(P_e)$  = 0.46 mm (Sec. 8.4.1)

##### Minimum Thickness - Testing Situation

$e_{st}$  = 1.93 mm (Eq. 7.4-2)  
 $e_{ot}$  = 7.17 mm (Sec. 9)

[SAVE](#)[EMAIL](#)[PRINT](#)

## CONICAL SHELL – DESIGN- AND DIMENSIONAL DATA

**Internal design pressure**  
See cylindrical shell, page 4.

**External design pressure**  
See cylindrical shell, page 4.

**Design temperature**  
See cylindrical shell, page 4.

**Joint coefficient**  
See cylindrical shell, page 4.

**Conical shell material**  
See cylindrical shell, page 4.

**Outer diameter of large end, DeL**  
Enter a positive value greater than zero, i.e. 600 mm for the outer diameter at the large end of the conical shell. Default value is 0 mm.

**Outer diameter of small end, DeS**  
Enter a positive value greater than zero, i.e. 300 mm for the outer diameter at the small end of the conical shell. Default value is 0 mm.

**Apex angle of shell, alfa**  
Enter a positive value greater than zero, i.e. 35° for the conical angle (apex). Values greater than 0° and up to and including 75° are acceptable.

**Radius of knuckle, rk**  
Inside radius at the transition between the connecting cylindrical shell and the conical shell. Enter a positive value greater than zero, i.e. 15 mm. Default value is 0 mm.

**Diameter of opening in shell, do**  
Enter a positive value greater than zero, i.e. 125 mm. The opening is calculated as an unreinforced opening which is a conservative approach in case a nozzle is present. The unreinforced opening is assumed to be located at the middle of the conical shell, see drawing below. Default value is 0 mm.

As the opening is assumed located at the middle of the conical shell, the user should be aware that openings located closer to the large end junction may require an increased thickness.

**Unsupported cylindrical length, Lcyl**  
Enter a positive value greater than zero for the unsupported length of the connecting cylindrical shell at the large end, i.e. 1500 mm. This value is sometimes necessary in case an external pressure is present. Default value is 0 mm.

Also see cylindrical shell, page 4.

### Drawing

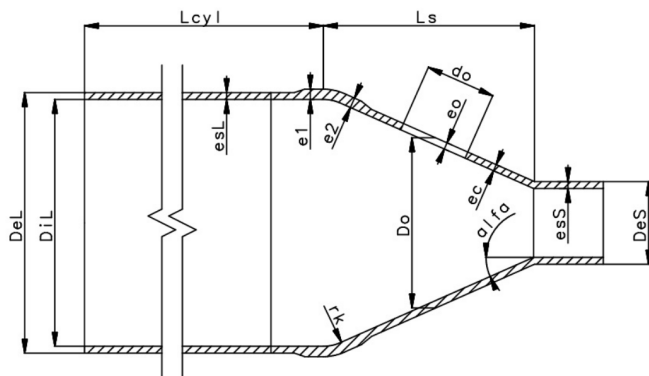

MAIN MENU
Conical Shell
DRAWING

DESIGN DATA

Internal design pressure [bar]	4
External design pressure [bar]	0.5
Design temperature [°C]	125
Joint coefficient	0.85
Conical shell material	1.0473

DIMENSIONAL DATA

Outer diameter of large end, DeL [mm]	600
Outer diameter of small end, DeS [mm]	300
Apex angle of shell, alfa [°]	35
Radius of knuckle, rk [mm]	15
Diameter of opening in shell, do [mm]	125
Unsupported cylindrical length, Lcyl [mm]	1500

CALCULATE
RESET



## CONICAL SHELL - RESULTS

### Input Parameters

See cylindrical shell, page 5.

### Calculated Result

See cylindrical shell, page 5.

### Calculation Info

For conical shells, the following info are further shown:

- Conical shell length,  $L_s$ .
- If present, diameter,  $D_o$ , where the center of the unreinforced opening is located.

Also see cylindrical shell, page 5.

### Calculation Details

This section shows in detail all the calculated minimum thicknesses for the design- and testing situation, with reference to formulas within the EN 13445-3 standard.

#### Design Situation

- $e_sL$  ( $P_i$ ): Shell thickness for the cylinder at the large end due to the internal pressure,  $P_i$

- $e_sS$  ( $P_i$ ): Shell thickness for the cylinder at the small end due to the internal pressure,  $P_i$

- $e_c$  ( $P_i$ ): Conical shell thickness due to the internal pressure,  $P_i$

- $e_c$  ( $P_e$ ): Conical shell thickness due to the external pressure,  $P_e$

- $e_1$  ( $P_i$ ): Cylindrical shell/knuckle thickness at the large end junction due to the internal pressure,  $P_i$

- $e_2$  ( $P_i$ ): Conical shell/knuckle thickness at the large end junction due to the internal pressure,  $P_i$

- $e_o$  ( $P_i$ ): Conical shell thickness due to the opening and internal pressure,  $P_i$

#### Testing Situation

- $e_sL_t$ : Shell thickness for the cylinder at the large end due to the internal testing pressure,  $P_T$

- $e_sS_t$ : Shell thickness for the cylinder at the small end due to the internal testing pressure,  $P_T$

- $e_{ct}$ : Conical shell thickness due to the internal testing pressure,  $P_T$ .

- $e_{1t}$ : Cylindrical shell/knuckle thickness at the large end junction due to the internal testing pressure,  $P_T$

- $e_{2t}$ : Conical shell/knuckle thickness at the large end junction due to the internal testing pressure,  $P_T$

- $e_{ot}$ : Conical shell thickness due to the opening and internal testing pressure,  $P_T$

The calculated maximum value will be the overall minimum thickness,  $e_{min}$ .

### Further Possibilities

See cylindrical shell, page 5.

### Drawing

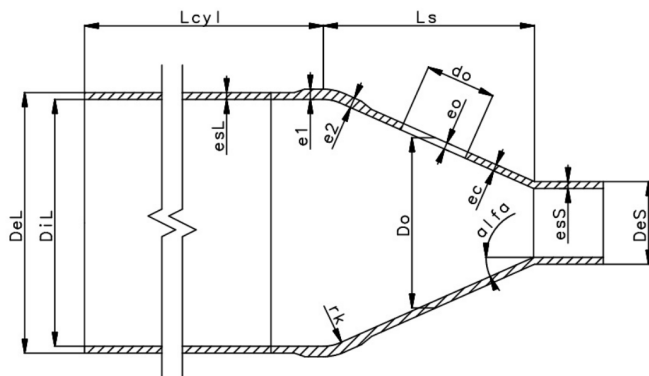

BACK

Conical Shell

#### INPUT PARAMETERS

Internal design pressure: 4.0 bar  
External design pressure: 0.5 bar  
Design temperature: 125 °C  
Joint coefficient: 0.85  
Conical shell material: 1.0473  
Outer diameter of large end,  $D_{eL}$ : 600 mm  
Outer diameter of small end,  $D_{eS}$ : 300 mm  
Apex angle of shell,  $\alpha$ : 35.0 deg  
Radius of knuckle,  $r_k$ : 15 mm  
Diameter of opening in shell,  $d_o$ : 125.0 mm  
Unsupported cylindrical length,  $L_{cyl}$ : 1500.0 mm

#### CALCULATED RESULT

Minimum thickness,  $e_{min}$  = 1.78 mm

#### CALCULATION INFO

Internal diameter,  $D_{iL}$  = 598.64 mm  
Conical length,  $L_s$  = 214.96 mm  
Shell diameter for opening,  $D_o$  = 450.52 mm  
Internal testing pressure,  $P_T$  = 5.7 bar  
Please add allowances

#### CALCULATION DETAILS

##### Minimum Thickness - Design Situation

$e_{sL}$  ( $P_i$ ) = 0.68 mm (Eq. 7.4-2)  
 $e_{sS}$  ( $P_i$ ) = 0.96 mm (Eq. 7.4-2/Sec. 7.6.8.2)  
 $e_c$  ( $P_i$ ) = 0.8 mm (Eq. 7.6-3)  
 $e_c$  ( $P_e$ ) = 0.97 mm (Sec. 8.5.2)  
 $e_1$  ( $P_i$ ) = 1.2 mm (Sec. 7.6.6/7.6.7)  
 $e_2$  ( $P_i$ ) = 1.2 mm (Sec. 7.6.6/7.6.7)  
 $e_o$  ( $P_i$ ) = 1.78 mm (Sec. 9.5)

##### Minimum Thickness - Testing Situation

$e_{sL_t}$  = 0.51 mm (Eq. 7.4-2)  
 $e_{sS_t}$  = 1.06 mm (Eq. 7.4-2/Sec. 7.6.8.2)  
 $e_{ct}$  = 0.6 mm (Eq. 7.6-3)  
 $e_{1t}$  = 1.1 mm (Sec. 7.6.6/7.6.7)  
 $e_{2t}$  = 1.1 mm (Sec. 7.6.6/7.6.7)  
 $e_{ot}$  = 1.61 mm (Sec. 9.5)

SAVE

EMAIL

PRINT

## KLÖPPER/KORBBOGEN END – DESIGN- AND DIMENSIONAL DATA

### Internal design pressure

See cylindrical shell, page 4.

### External design pressure

See cylindrical shell, page 4.

### Design temperature

See cylindrical shell, page 4.

### Joint coefficient

For torispherical- and ellipsoidal ends there is a possibility to select a joint coefficient of 1.00 if the material is austenitic and the end is seamless and cold spun during the manufacturing process. This may result in a smaller thickness.

Also see cylindrical shell, page 4.

### Klöppler/korbbogen material

See cylindrical shell, page 4.

### Outer diameter of end, $D_e$

Enter a positive value greater than zero, ie. 1400 mm. Default value is 0 mm.

### Diameter of opening in end, $d_o$

Enter a positive value greater than zero, ie. 350 mm. The opening is located entirely within the central part of the end, defined by the diameter  $0.8 \cdot D_e$ . The opening is calculated as an unreinforced opening which is a conservative approach in case a nozzle is present. Default value is 0 mm.

### Diameter of opening in knuckle, $d_{ib}$

Enter a positive value greater than zero, ie. 200 mm. The opening is partly or fully located within the knuckle part of the end (greater than the diameter  $0.8 \cdot D_e$ ). Default value is 0 mm.

### Drawing

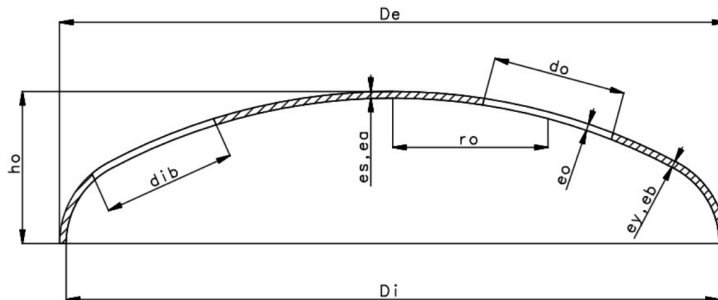

MAIN MENU
Klöppler End
DRAWING

DESIGN DATA

Internal design pressure [bar]	10
External design pressure [bar]	1
Design temperature [°C]	158
Joint coefficient	1.0
Klöppler end material	1.0473

DIMENSIONAL DATA

Outer diameter of end, $D_e$ [mm]	1400
Diameter of opening in end, $d_o$ [mm]	350
Diameter of opening in knuckle, $d_{ib}$ [mm]	200

CALCULATE
RESET

BACK
Joint Coefficient

Please note that there may be special requirements concerning the choice of a proper joint coefficient.

- 1.00 - Testing Group 1 and 2
- 0.85 - Testing Group 3
- 0.70 - Testing Group 4
- 1.00 - Seamless Part
- 1.00 - Cold Spun, Seamless, Austenitic

## KLÖPPER/KORBBOGEN END - RESULTS

### Input Parameters

See cylindrical shell, page 5.

### Calculated Result

See cylindrical shell, page 5.

### Calculation Info

For torispherical- and ellipsoidal ends the following info are further shown:

- Calculation notes
- Outer height of the end,  $h_o$
- If present, max. center radius,  $r$ , for the opening in the central part.

Also see cylindrical shell, page 5.

### Calculation Details

This last section shows in detail all the calculated minimum thicknesses for the design- and testing situation, with reference to formulas within the EN 13445-3 standard.

#### Design Situation

- $e_s$  ( $P_i$ ): Thickness of the spherical part of the end due to the internal pressure,  $P_i$
- $e_y$  ( $P_i$ ): Thickness of the knuckle to avoid axisymmetric yielding due to the internal pressure,  $P_i$
- $e_b$  ( $P_i$ ): Thickness of the knuckle to avoid plastic buckling due to the internal pressure,  $P_i$
- $e_o$  ( $P_i$ ): Thickness of the spherical part of due to the opening and internal pressure,  $P_i$
- $e_a$  ( $P_e$ ): thickness of the end due to the external pressure,  $P_e$
- $e_y$  ( $P_e$ ): Thickness of the knuckle to avoid axisymmetric yielding due to the external pressure,  $P_e$ , used as internal pressure,  $P_i$

#### Testing Situation

- $e_{st}$ : Thickness of the spherical part of the end due to the internal testing pressure,  $P_T$
- $e_{yt}$ : Thickness of the knuckle to avoid axisymmetric yielding due to the internal testing pressure,  $P_T$
- $e_{bt}$ : Thickness of the knuckle to avoid plastic buckling due to the internal testing pressure,  $P_T$
- $e_{ot}(P_i)$ : Thickness of the spherical part of due to the opening and internal testing pressure,  $P_T$

The calculated maximum value will be the overall minimum thickness,  $e_{min}$ .

### Further Possibilities

See cylindrical shell, page 5.

### Drawing

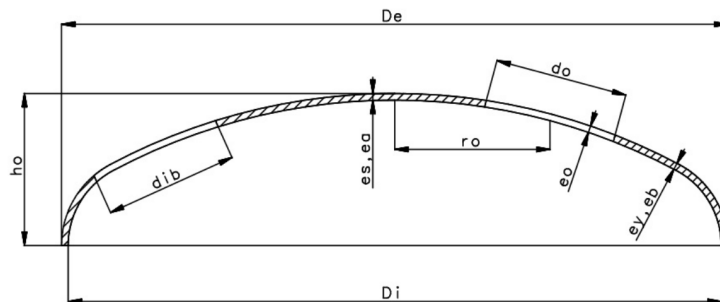

BACK

Klöpfer End

#### INPUT PARAMETERS

Internal design pressure: 10.0 bar  
External design pressure: 1.0 bar  
Design temperature: 158 °C  
Joint coefficient: 1.0  
Klöpfer end material: 1.0473  
Outer diameter of end,  $D_e$ : 1500 mm  
Diameter of opening in end,  $d_o$ : 350.0 mm  
Diameter of opening in knuckle,  $d_{ib}$ : 150 mm  
Cold spun, seamless, austenitic: No

#### CALCULATED RESULT

Minimum thickness,  $e_{min}$  = 8.13 mm

#### CALCULATION INFO

Thickness,  $e_b$ , needs not to be considered (Sec. 7.5.3.2, Note 3)  
Max. radius for opening in spherical part,  $r_o$  = 281.94 mm  
Radius,  $r$ , based upon calculated  $e_{min}$   
Internal diameter,  $D_i$  = 1483.74 mm  
Outer height,  $h_o$  = 294.79 mm  
Internal testing pressure,  $P_T$  = 14.3 bar  
Please add allowances

#### CALCULATION DETAILS

##### Minimum Thickness - Design Situation

$e_s$  ( $P_i$ ) = 3.82 mm (Eq. 7.5-1)  
 $e_y$  ( $P_i$ ) = 7.53 mm (Eq. 7.5-2)  
 $e_b$  ( $P_i$ ) = 6.43 mm (Eq. 7.5-3)  
 $e_o$  ( $P_i$ ) = 8.13 mm (Sec. 9)  
 $e_a$  ( $P_e$ ) = 2.78 mm (Sec. 8.7.1)  
 $e_y$  ( $P_e$ ) = 1.09 mm (Sec. 8.8.2)

##### Minimum Thickness - Testing Situation

$e_{st}$  = 3.18 mm (Eq. 7.5-1)  
 $e_{yt}$  = 6.5 mm (Eq. 7.5-2)  
 $e_{bt}$  = 5.69 mm (Eq. 7.5-3)  
 $e_{ot}$  = 7.03 mm (Sec. 9)

SAVE

EMAIL

PRINT

## ELLIPSOIDAL END – DESIGN- AND DIMENSIONAL DATA

### **Internal design pressure**

See cylindrical shell, page 4.

### **External design pressure**

See cylindrical shell, page 4.

### **Design temperature**

See cylindrical shell, page 4.

### **Joint coefficient**

See klöpper/korbbogen end, page 8.

### **Ellipsoidal end material**

See cylindrical shell, page 4.

### **Outer diameter of end, $D_e$**

See klöpper/korbbogen end, page 8.

### **Shape factor for end, $K$**

A shape factor from 1.7 to 2.2 should be used acc. EN 13445-3, Sec. 7.5.4.

Using a value of two equals a 2:1 ellipsoidal end.

### **Diameter of opening in end, $d_o$**

See klöpper/korbbogen end, page 8.

### **Diameter of opening in knuckle, $d_{ib}$**

See klöpper/korbbogen end, page 8.

### **Drawing**

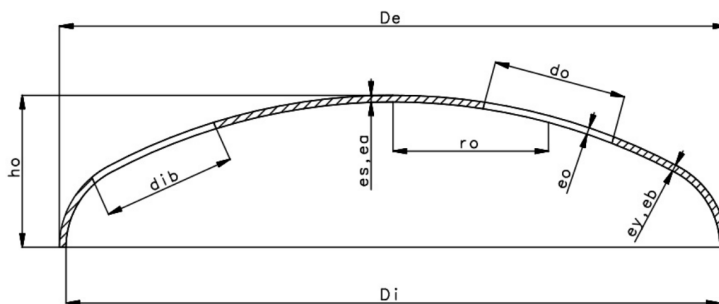

MAIN MENU		Ellipsoidal End		DRAWING	
DESIGN DATA					
Internal design pressure [bar]					8
External design pressure [bar]					1
Design temperature [°C]					175
Joint coefficient					1.0
Ellipsoidal end material					1.4435
DIMENSIONAL DATA					
Outer diameter of end, $D_e$ [mm]					2000
Shape factor for end, $K$ [-]					2
Diameter of opening in end, $d_o$ [mm]					150
Diameter of opening in knuckle, $d_{ib}$ [mm]					75
CALCULATE		RESET			

## ELLIPSOIDAL END – RESULTS

### Input Parameters

See cylindrical shell, page 5.

### Calculated Result

See cylindrical shell, page 5.

### Calculation Info

See klöpper/korbbogen end, page 9.

### Calculation Details

See klöpper/korbbogen end, page 9.

### Further Possibilities

See cylindrical shell, page 5.

### Drawing

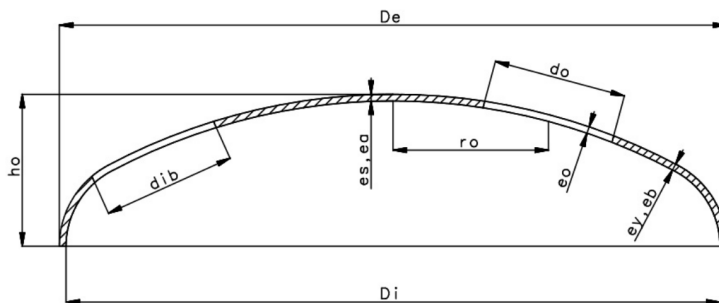

BACK

Ellipsoidal End

#### INPUT PARAMETERS

Internal design pressure: 8.0 bar  
External design pressure: 1.0 bar  
Design temperature: 175 °C  
Joint coefficient: 1.0  
Ellipsoidal end material: 1.4435  
Outer diameter of end,  $D_e$ : 2000 mm  
Diameter of opening in end,  $d_o$ : 150.0 mm  
Diameter of opening in knuckle,  $d_{ib}$ : 75 mm  
Shape factor for end,  $K$ : 2  
Cold spun, seamless, austenitic: Yes

#### CALCULATED RESULT

Minimum thickness,  $e_{min}$  = 7.96 mm

#### CALCULATION INFO

Max. radius for opening in spherical part,  $r_o$  = 800.12 mm  
Radius,  $r$ , based upon calculated  $e_{min}$   
Internal diameter,  $D_i$  = 1984.08 mm  
Outer height,  $h_o$  = 503.98 mm  
Internal testing pressure,  $P_T$  = 14.1 bar  
**Please add allowances**

#### CALCULATION DETAILS

##### Minimum Thickness - Design Situation

$e_s(P_i)$  = 5.52 mm (Eq. 7.5-1)  
 $e_y(P_i)$  = 7.67 mm (Eq. 7.5-2)  
 $e_b(P_i)$  = 6.01 mm (Eq. 7.5-3)  
 $e_o(P_i)$  = 7.96 mm (Sec. 9)  
 $e_a(P_e)$  = 4.03 mm (Sec. 8.7.1)  
 $e_y(P_e)$  = 1.2 mm (Sec. 8.8.2)

##### Minimum Thickness - Testing Situation

$e_{st}$  = 4.6 mm (Eq. 7.5-1)  
 $e_{yt}$  = 6.53 mm (Eq. 7.5-2)  
 $e_{bt}$  = 5.21 mm (Eq. 7.5-3)  
 $e_{ot}$  = 6.81 mm (Sec. 9)

SAVE

EMAIL

PRINT

## HEMISPHERICAL END – DESIGN- AND DIMENSIONAL DATA

### **Internal design pressure**

See cylindrical shell, page 4.

### **External design pressure**

See cylindrical shell, page 4.

### **Design temperature**

See cylindrical shell, page 4.

### **Joint coefficient**

See cylindrical shell, page 4.

### **Hemispherical end material**

See cylindrical shell, page 4.

### **Outer diameter of end, $D_e$**

See klöpper/korbbogen end, page 8.

### **Diameter of opening in end, $d_o$**

See cylindrical shell, page 4.

### **Drawing**

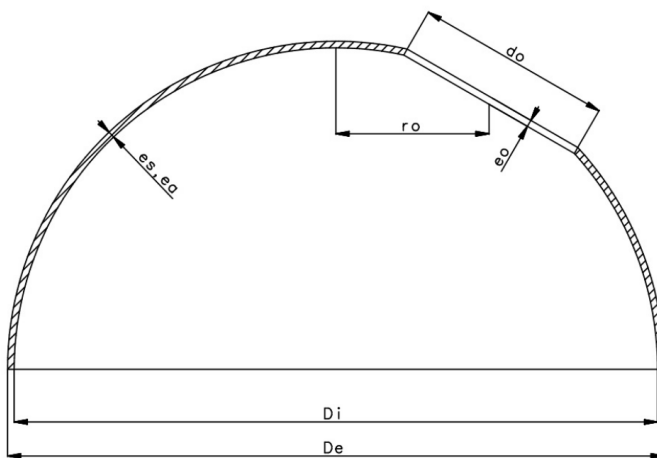

Hemispherical End	
DESIGN DATA	
Internal design pressure [bar]	12
External design pressure [bar]	1
Design temperature [°C]	85
Joint coefficient	1.0
Hemispherical end material	1.5415
DIMENSIONAL DATA	
Outer diameter of end, $D_e$ [mm]	750
Diameter of opening in end, $d_o$ [mm]	200
CALCULATE	RESET

## HEMISPHERICAL END – RESULTS

### Input Parameters

See cylindrical shell, page 5.

### Calculated Result

See cylindrical shell, page 5.

### Calculation Info

See klöpper/korbbogen end, page 9.

### Calculation Details

This section shows in detail all the calculated minimum thicknesses for the design- and testing situation with reference to formulas within the EN 13445-3 standard.

#### Design Situation

- es (Pi): Hemispherical end thickness due to the internal pressure, Pi
- eo (Pi): Hemispherical end thickness due to the opening and internal pressure, Pi
- ea (Pe): Hemispherical end thickness due to the external pressure, Pe

#### Testing Situation

- est: Hemispherical end thickness due to the internal testing pressure, PT
- eot: Hemispherical end thickness due to the opening and internal testing pressure, PT

The calculated maximum value will be the overall minimum thickness,  $e_{min}$ .

### Further Possibilities

See cylindrical shell, page 5.

### Drawing

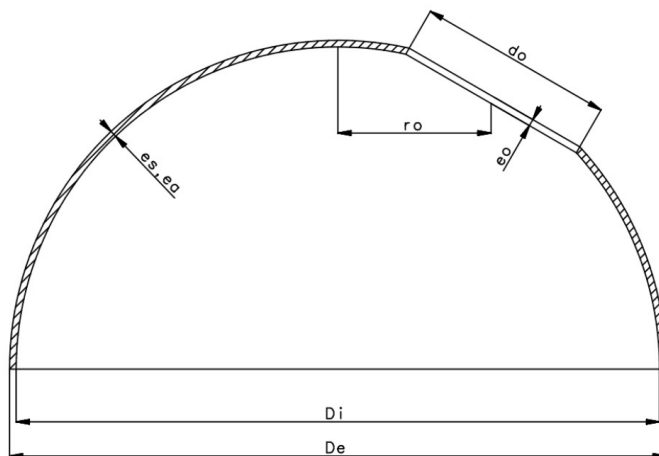

BACK

Hemispherical End

#### INPUT PARAMETERS

Internal design pressure: 12.0 bar  
External design pressure: 1.0 bar  
Design temperature: 85 °C  
Joint coefficient: 1.0  
Hemispherical end material: 1.5415  
Outer diameter of end,  $D_e$ : 750 mm  
Opening in spherical part,  $d_o$ : 200 mm

#### CALCULATED RESULT

Minimum thickness,  $e_{min}$  = 3.71 mm

#### CALCULATION INFO

Max. radius for opening in spherical part,  $r_o$  = 341.86 mm  
Radius,  $r$ , based upon calculated  $e_{min}$   
Internal diameter,  $D_i$  = 742.57 mm  
Internal testing pressure,  $P_T$  = 17.16 bar  
**Please add allowances**

#### CALCULATION DETAILS

##### Minimum Thickness - Design Situation

$e_s$  (Pi) = 1.27 mm (Eq. 7.4-5)

$e_o$  (Pi) = 3.71 mm (Sec. 9)

$e_a$  (Pe) = 0.68 mm (Sec. 8.7.1)

##### Minimum Thickness - Testing Situation

$e_{st}$  = 1.23 mm (Eq. 7.4-5)

$e_{ot}$  = 3.63 mm (Sec. 9)

SAVE

EMAIL

PRINT

## WELDED FLAT END – DESIGN- AND DIMENSIONAL DATA

### Internal design pressure

See cylindrical shell, page 4.

### Design temperature

See cylindrical shell, page 4.

### Joint coefficient

See cylindrical shell, page 4.

### Flat end material

Select the material for the flat end.

Also see cylindrical shell, page 4.

### Cylindrical shell material

Select the material for the adjoining cylindrical shell.

Also see cylindrical shell, page 4.

### Outer diameter of end, $D_e$

See cylindrical shell, page 4.

### Thickness of cylindrical shell

Enter a value for the cylindrical shell, i.e. 5 mm. If the entered value is lower than the required minimum value for a cylindrical shell, which is calculated automatically, then the minimum value will be used. Default value is 0 mm.

The entered value should not include any allowances, i.e. a 6 mm nominal shell thickness with 1 mm corrosive allowance and 0.3 mm negative allowance should be entered as:  $6 - 1 - 0.3 = 4.7$  mm.

Also see cylindrical shell, page 4.

### Diameter of opening in end, $d_o$

Enter a value for the opening in the welded flat end, i.e. 150 mm. The opening is located at the center of the end. Default value is 0 mm.

### Drawing

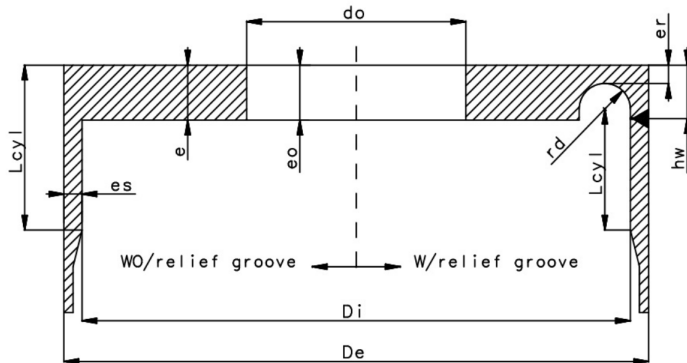

MAIN MENU
Welded Flat End
DRAWING

DESIGN DATA

Internal design pressure [bar]	<input style="width: 60px;" type="text" value="4"/>
Design temperature [°C]	<input style="width: 60px;" type="text" value="140"/>
Joint coefficient	<input style="width: 60px;" type="text" value="0.85"/>
Flat end material	<input style="width: 60px;" type="text" value="1.0425"/>
Cylindrical shell material	<input style="width: 60px;" type="text" value="1.0473"/>

DIMENSIONAL DATA

Outer diameter of end, $D_e$ [mm]	<input style="width: 60px;" type="text" value="900"/>
Thickness of cylindrical shell, $e_s$ [mm]	<input style="width: 60px;" type="text" value="5"/>
Diameter of opening in end, $d_o$ [mm]	<input style="width: 60px;" type="text" value="150"/>

CALCULATE
RESET



## WELDED FLAT END – RESULTS

### Input Parameters

See cylindrical shell, page 5.

### Calculated Result

See cylindrical shell, page 5.

### Calculation Info

For welded flat end ends the following info are further shown:

- Info about C1 and C2 factors
- Min. length of the cylindrical shell having thickness,  $e_s$
- If present, info about the relief groove and minimum thickness above the relief groove including location of welded joint. Also consult EN 13445-3, Sec. 10.4.2.4

### Calculation Details

This section shows in detail all the calculated minimum thicknesses for the design- and testing situation with reference to formulas within the EN 13445-3 standard.

#### Design Situation

- e (C1): Flat end thickness due to internal pressure,  $P_i$ , provided a simplified fatigue assessment for the flat end to shell junction is carried out
- e (C2): Flat end thickness due to internal pressure,  $P_i$  (no fatigue assessment necessary)
- eo: Flat end thickness due to the opening and internal pressure,  $P_i$
- eo (C1): Flat end thickness due to the opening and internal pressure,  $P_i$ , provided a simplified fatigue assessment for the flat end to shell junction is carried out

#### Testing Situation

- et: Flat end thickness due to the internal testing pressure,  $P_T$
- eot: Flat end thickness due to the opening and internal testing pressure,  $P_T$

The calculated maximum value will be the overall minimum thickness,  $e_{min}$ .

### Further Possibilities

See cylindrical shell, page 5.

### Drawing

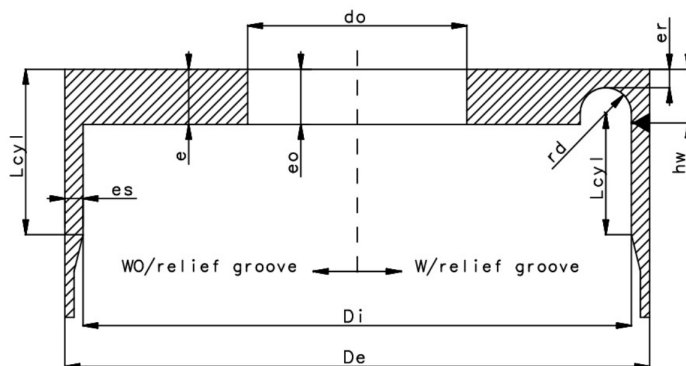

BACK

Welded Flat End

#### INPUT PARAMETERS

Internal design pressure: 4.0 bar  
Design temperature: 140.0 °C  
Joint coefficient: 0.85  
Flat end material: 1.0425  
Cylindrical shell material: 1.0473  
Outer diameter of end,  $D_e$ : 900.0 mm  
Thickness of cylindrical shell,  $e_s$ : 5.0 mm  
Diameter of opening in end,  $d_o$ : 150.0 mm

#### CALCULATED RESULT

Minimum thickness,  $e_{min}$  = 26.44 mm

#### CALCULATION INFO

Thickness based upon value of C2 factor  
Consider C1 only if fatigue life is calculated, Sec. 10.4.4.4

Internal diameter,  $D_i$  = 890.0 mm  
Length, min.  $L_{cyl}$  = 66.9 mm  
End w/relief groove, min.  $er$  = 6.77 mm  
End w/relief groove, min.  $rd$  = 5.0 mm  
End w/relief groove, min.  $hw$  = 24.44 mm  
End w/relief groove, see Sec. 10.4.2.4  
Internal testing pressure,  $P_T$  = 5.84 bar  
**Please add allowances**

#### CALCULATION DETAILS

##### Minimum Thickness - Design Situation

e (C1) = 18.46 mm (Eq. 10.4-10)

e (C2) = 24.86 mm (Eq. 10.4-10)

eo = 26.44 mm (Eq. 10.6-1)

eo (C1) = 20.24 mm (Eq. 10.6-1)

##### Minimum Thickness - Testing Situation

et = 17.18 mm (Eq. 10.4-12)

eot = 18.84 mm (Eq. 10.6-1)

SAVE

EMAIL

PRINT